

Date Data	Drawn Rys.	App'd Zatw.	Revision Rewizja	No. Nr.	Mark Oznac.

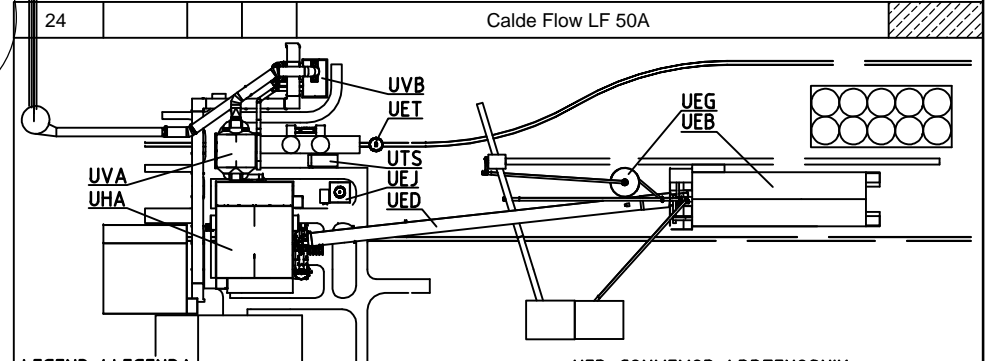
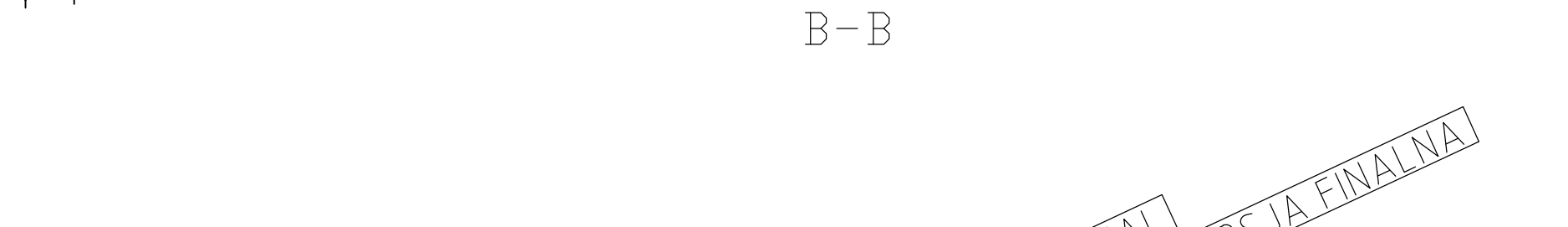
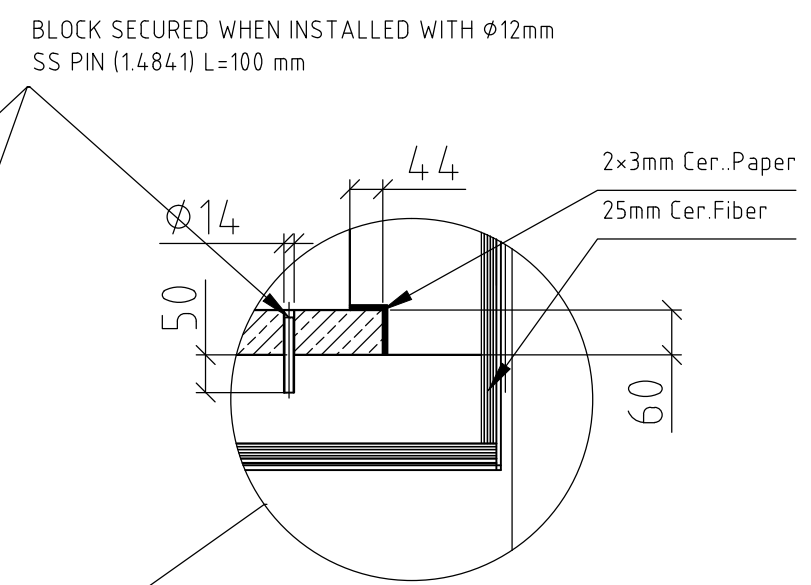
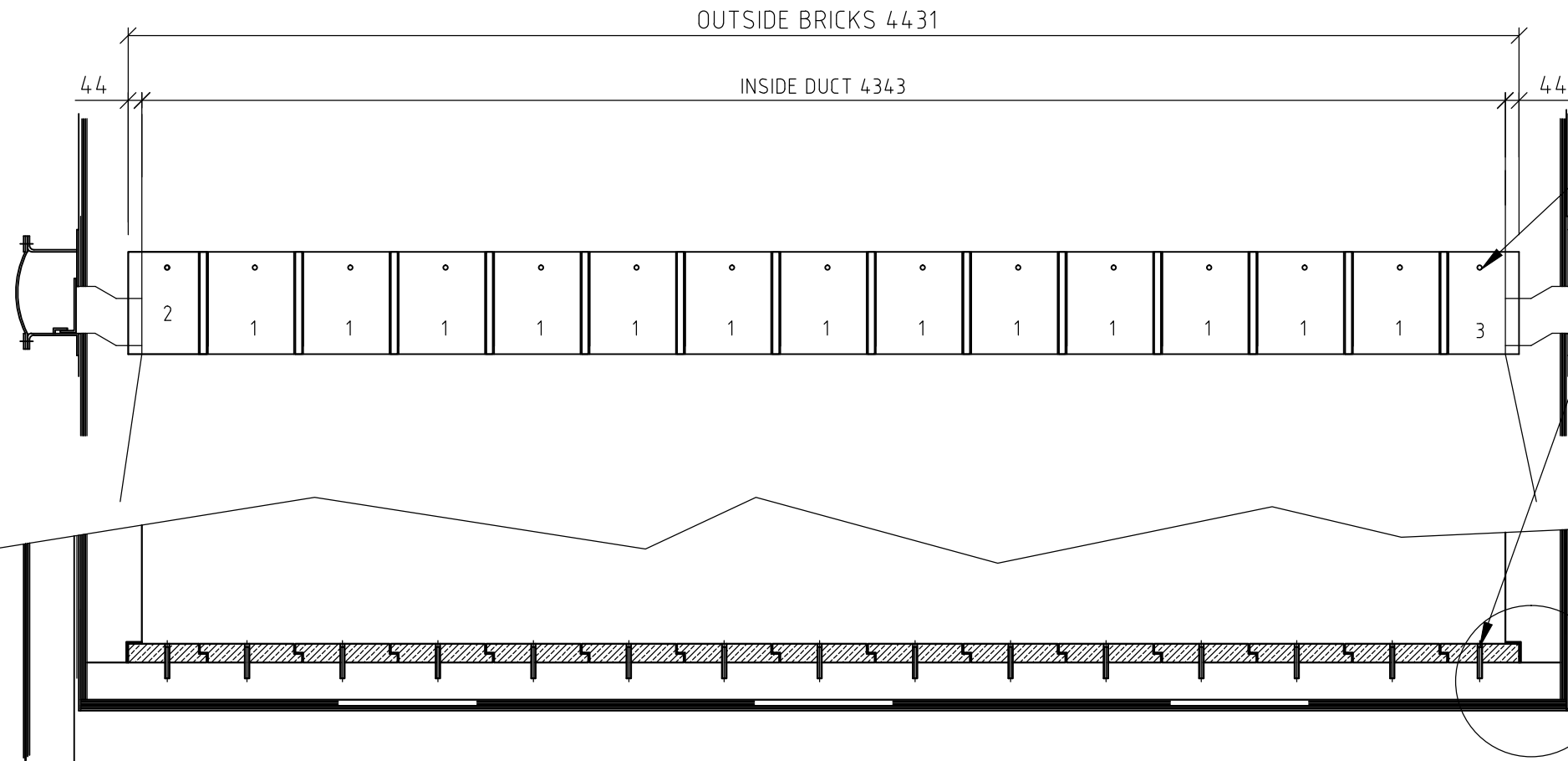

LEGENDA / LEGENDA
 UHA BOILER HOUSE / KOTLOWNIA
 UVA ELECTRICAL PRECIPITATOR / ELEKTROFILTR
 UVB ID-FAN ROOM / POMIESZCZENIE WENTYLATORA SPALIN
 UEB A-BARN / MAGAZYN A
 UED CONVEYOR / PRZENOSNIK
 UTS AMMONIA TANK / ZBIORNIK AMONIAKU
 UET FLYASH SILO / SILOS POPIOLU LOTNEGO
 UEJ OIL TANK / ZBIORNIK OLEJU
 UEG AGRO-SILO / ZBIORNIK BIOMASY

NUMBERS FOR 1 SEPARATOR

FINAL WERSJA FINALNA

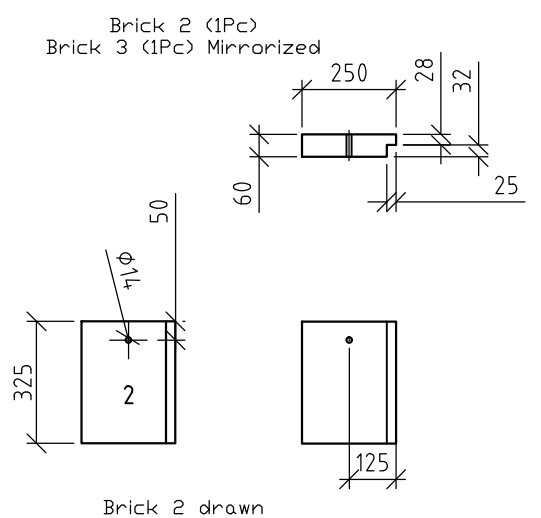
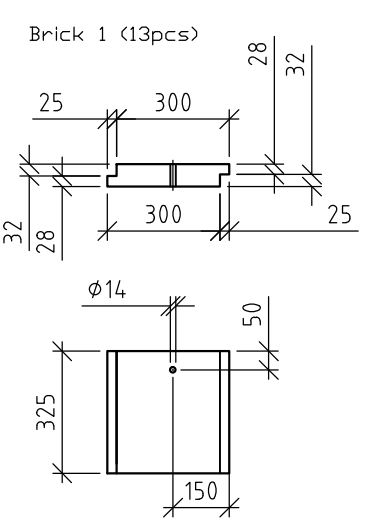

THIS DOCUMENT AND ANY INFORMATION HEREIN CONTAINED ARE THE PROPERTY OF FOSTER WHEELER CORPORATION. THE UNAUTHORIZED COPYING BY, USE BY, OR DISCLOSURE TO PERSONS WHO ARE NOT ENTITLED TO RECEIPT OF SUCH DISCLOSURE, OR DISCLOSURE TO PERSONS WHO ARE LIKELY TO MISUSE THIS DOCUMENT OR INFORMATION, IS PROHIBITED. ANY BREACH AGAINST THE ABOVE PROHIBITION IS LIABLE TO ENFORCEMENT, WITH DAMAGES PAYABLE TO THOSE AGGRIEVED AND OTHER REMEDIES AVAILABLE BY LAW OR EQUITY.

TEN DOKUMENT I INFORMACJE W NIM ZAWARTE SA WLASNOSCIA KORPORACJI FOSTER WHEELER. NIELEGALNE KOPIOWANIE, UZYTKOWANIE LUB UJAWNIANIE OSOBOM NIEUPRAWNIONYM LUB UJAWNIANIE OSOBOM, KTORE PRAWDOPODOBNIENIE NEWLASCWIE ZASTOSUJA TEN DOKUMENT LUB INFORMACJE W NIM ZAWARTE JEST ZAKAZANE. ZLAMANIE POWYZSZYCH ZAKAZOW PODLEGA USTAWOWO WPLACIE KARNEGO ODSZKODOWANIA LUB NARAZA UZYTKOWNIKA NA ZASTOSOWANIE INNEGO SPOSOBU KARANIA PRZEWIDZIANEGO PRZEZ PRAWO I SPRAWIEDLIWOSC.

Client Klient	GDF SUEZ		
Client Klient	GDF SUEZ Energia Polska S.A.		
Project Projekt	Polanec Green Unit		
Main Assembly Nazwa Projektu	CFB 158.3/135.1 kg/s, 127.5/19.5 bar, 535/535 °C		
Title Tytuł rys.	EXPANSION COD-Conv.Cage		
Dwg. size Wielkosc rys.	A3	Date Data	09.09.2011
Designed Konstruował	Jörn	Work No. Nr pracy	Scale Skala
Sub. Checked Podw. Sprawdzil		Sub Contractor Dwg. No. Nr rys. poddostawcy	1:20 (-)
Sub. Approved Podw. Zatwierdzil		KKS Dwg. No. Nr rys. Dwg. KKS	Weight Ciężar
FW Checked FW Sprawdzil	SKN		kg
FW Approved FW Zatwierdzil	AOK		
			953-FWHBC++++-MTC5115 ₁

PLOT DATE, TIME: 29.12.2011, 12:33